



INSTALLATION AND OPERATIONS MANUAL

DIGITAL TEMPERATURE AND POWER MONITOR

DTPM-1000 and DTPM-3000 SERIES

(REV 1.0 04/14/20)

DTPM 1000 Series



DTPM 3000 Series



DIGITAL INSTRUMENTS TEMPERATURE POWER MONITOR

The Digital Temperature Power Monitor (DTPM) is designed to display temperature, and to warn of temperature and power supply failures occurring in most controlled temperature applications. When an improper temperature is reached, or the power supply is interrupted, the DTPM system provides a visual and audible signal. It is designed to provide a different visual and audible signal for each type of occurrence.

The DTPM series monitors are equipped with a replaceable alkaline 9V battery. In the event of a power failure, the DTPM will continue to operate and monitor for a problem for approximately 2 hours. Under normal conditions, the battery should be replaced annually, or when the on/off audible signal is given for low battery.

The DTPM system comes standard with a features that allows it to be connected to an existing remote powered station, or to a Digital Instruments, Inc. DTPMR Remote Location Monitor. The DTPMR, is available for those not wishing to connect the DTPM to their existing master remote station. In the event of a failure, the DTPMR will signal the same visual and audible warnings as those being displayed at the DTPM master station. A chart describing these signals is included in this manual. When a remote monitor is used, a copy of the chart should be kept at the remote location where 24 Hour monitoring will take place.

The DTPM is available in a wide range of factory configured temperature categories. The DTPM-1000 series of monitors provide dual high and low temperature alarm settings, and the DTPM-3000 series of monitors provide a single high temperature setting. The temperature display and alarm settings have an accuracy of +/- 0.1°C. (See the Styles of DTPM Monitor Chart for additional information.)

The DTPM series of systems operate on standard 115VAC @ 60Hz or 220VAC @ 50/60Hz. Units operating on 115VAC are powered by an AC receptacle mounted power supply, and 220VAC units are hard wired to the AC supply.

DTPM INSTALLATION INSTRUCTIONS

- (1) Mount the DTPM and your solution bottle at a convenient location on the blood bank refrigerator or plasma freezer. The DTPM has keyhole mounting holes on 4.25" centers, which allow the user to mount the unit without disassembling the case. Use #6 or #8 stainless steel pan head screws for best results.
- (2) Fill the solution bottle with the appropriate solution:
 - a. Blood bank and other refrigerators – 10% glycerin and 90% water.
 - b. Plasma and other freezers – 50% glycol and 50% water.
- (3) Assemble the quick disconnect plug to the temperature sensor by aligning the indicators located on the plug and receptacle. This will complete the temperature sensing circuit.
- (4) Insert the sensor through the refrigerator/freezer access hole and position it in the solution bottle. The top of the bottle should be sealed to prevent evaporation. Also seal the wiring access hole with sealing compound. Leave enough wire slack to allow the unit to be removed from its mounting position when the battery needs to be replaced.
- (5) Temporarily remove the unit from the mounting location. Connect the 9V alkaline battery to the battery clip located in the battery recess at the back of the DTPM. Insert the battery into the recess, and reinstall the unit on its mounting screws. Immediately connect AC power to the DTPM using the same electrical outlet being used to power the refrigeration equipment. (NOTE: The DTPM will sound the power fail alarm after the battery is connected, and until AC power is connected.)
- (6) A complete Quality Control Procedure should be performed on the equipment being monitored, as well as the DTPM system, prior to storage of products to insure proper operation. A suggested Quality Control Procedure is included in this manual.
- (7) Training of personnel should be initiated at this time.

DTPM OPERATION (ALL MODELS)

- (1) Normal Operation – When the temperature is in the safe range, AC power is normal, and the backup battery is good, the red LED digital display will be displaying a temperature value, and the green SAFE LED will be on. The audible alarm signal is silent.
- (2) Temperature Failure – If an out of range temperature is detected, the green SAFE LED will be off, the red HIGH or LOW LED will be illuminated, and the audible alarm will sound.
- (3) Silence Timer Feature – When an alarm condition is occurring, the audible alarm can be silenced by pressing either the 5 minute or 45 minute selection switch. If the error condition is cleared during the silence period, the DTPM will automatically cancel the remaining silence time.
- (4) AC Power Failure – In the event of an AC power failure, the DTPM will continue to monitor temperature using backup battery power. The Digital LED display will extinguish, a constant audible alarm will sound, and the green SAFE LED will flash. If an out of range temperature occurs, the appropriate red HIGH or LOW LED will flash, and the audible alarm will continue to sound.
- (5) Battery Test – The battery should be tested regularly by pushing the Battery Test Switch. No change in operation will occur if the battery is good. If the battery has become weak, an on/off audible signal will sound without having any indicator changes. The unit will turn off or act erratically if the battery is discharged to a level that it will not be serviceable. To ensure that battery backup power is sufficient, replace the battery annually and when the test indicates a weak or discharged battery. NOTE: The backup battery is slightly discharged each time the battery test is run. Run the battery test for as short a time period as possible.
- (6) See the "GUIDE TO DTPM WARNING INDICATOR" table in this manual.

DTPM REMOTE (DTPMR) INTERFACE

Remote Interface Operation – The DTPM can be connected to a Digital Temperature Monitor, Remote (DTPMR) using a proprietary interface signal. The DTPMR will replicate the green SAFE, red HIGH, LOW, and POWER LEDs, and the audible alarm indicators of the DTPM. The backup battery status of the DTPMR is also displayed. Review the DTPMR manual for a complete description of the DTPMR operation.

- (1) DTPM to DTPMR Wiring - The DTPM is connected to the DTPMR by connecting the R+ on both units, and the R- on both units. The connecting wires should be #24 through #20 AWG wire, and may be run up to 2600 feet. Twisted pair or two conductor shielded wire may be used. If shielded wire is used, ground the shield to chassis of earth ground.
- (2) A-B Switch Setting - Set the A-B switch to position A to enable the correct communications protocol for a DTPMR. Contact Digital Instruments, Inc. for specifications on the switch B option.

REMOTE LOCAL CONTACT MONITOR INTERFACE

The DTPM series of monitors, that operate off 110VAC, provide a normally open/normally closed single pole, double throw (SPDT) signaling relay.

- (1) Local Monitor Operation - NO/NC relay contacts are provided to signal that all conditions are safe, or that one or more conditions are alarming. An all safe condition energizes the relay, and the presence of any alarm de-energizes the relay.
- (2) Monitor wiring – The monitoring device is wired to either the NO or NC terminals, and the C terminal. A two conductor, 20 – 24 AWG wire is recommended. The wire length may be up to 2600 feet.
- (3) Relay Circuit Characteristics – The relay is rated for resistive loads at 115VAC @ 1 amp or 28VDC at 1 amp. Signaling current must be provided by the device monitoring the relay.

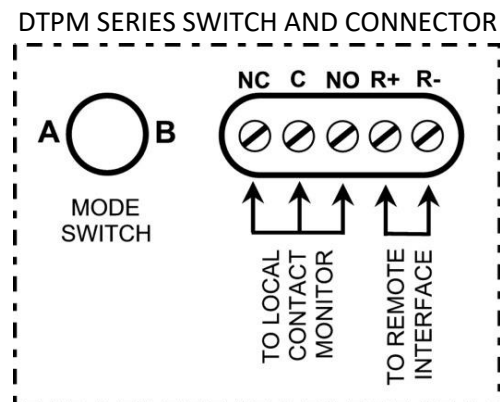

USER SUPPLIED CONTACT MONITOR INTERFACE – Connect the appropriate DTPM terminals, using a two conductor cable, to the user's existing remote monitor location. Connect to either the normally open and common, or normally closed and common terminals, depending on the polarity of the monitoring device. Signaling current must be supplied by the remote monitoring device.

- (1) The relay is energized when the green SAFE LED is on, and the measured temperature is within the operating range.
- (2) The relay is de-energized when one of the red LEDs is on to indicate an out of range temperature is detected, or the green SAFE LED is flashing indicating a power fault.

SUGGESTED DTPM QUALITY CONTROL TEST PROCEDURE

- (1) Low Temperature Alarm Activation (DTPM1 +1.5°C)
 - a. Fill an 8 ounce glass half full of chilled water (+4°C).
 - b. Crush ice into 1/8" particles in a separate container.
 - c. Remove the probe from the solution bottle, tape or rubber band to a test thermometer (NBS certified), then insert it into the glass of water. The test sensor and thermometer must be at the same level.
 - d. Slowly add crushed ice to provide a temperature drop of no more than 0.5°C per minute.
 - e. Stir the test thermometer and probe in a circular motion, keeping the ends in the lower liquid, not the upper slurry.
 - f. Log the lower alarm activation temperature shown on the DTPM, and verify that it matches the temperature shown on the thermometer.

- (2) High Temperature Alarm Activation (DTPM1, +5.5°C, DTPM3, -20°C)
 - a. 5.5°C – Slowly add warm water to the ice slurry to provide a temperature rise of no more than 0.5°C per minute.
 - b. -20°C – Slowly add warm water to a container of pre-cooled antifreeze solution (-30°C) to provide a temperature rise of no more than 0.5°C per minute.
 - c. Stir the test thermometer and probe in a circular motion, keeping the ends in the lower liquid, not the upper ice slurry.
 - d. Log the high alarm activation temperature shown on the DTPM, and verify that it matches the temperature shown on the thermometer.

- (3) Depress the calibration check button. Verify that the results are:
DTPM1: +10°C
DTPM3: -20°C

- (4) Activate the battery test switch to test the battery.

GUIDE TO DTPM WARNING INDICATORS

Condition of AC and Battery	Condition of Temperature	Temperature Status Indicators (Visual)			Audible Alarm
		Low	Safe	High	
Normal	Safe	Off	On	Off	Silent
Normal	Above High Limit	Off	Off	On	On
Normal	Below Low Limit	On	Off	Off	On
AC Failure	Safe	Off	Flashing	Off	On
AC Failure	Above High Limit	Off	Off	Flashing	On
AC Failure	Below Low Limit	Flashing	Off	Off	On
Low Battery	Safe	Off	On	Off	Beep

Alarm Reset Instructions: To silence the audible signal, select the desired amount of mute time (5 or 45 minutes), and press the appropriate Push to Silence button. The red HIGH or LOW LED will stay illuminated until the temperature returns to normal. When the alarm condition ends, the red LED will go off, and the green SAFE LED will illuminate. The audible signal is silenced for the selected mute time period. It will be reactivated if the alarm condition continues after the alarm mute time.

DTPM CONFIGURATIONS

The Digital Power and Temperature Monitors are available in a wide range of temperature and power source configurations. DTPM-1000 series units are designed for refrigeration use with dual high and low temperature alarms. The DTPM-3000 series units are designed for freezer operation, and have single high temperature alarms.

STANDARD DTPM CONFIGURATIONS

MODEL	DESCRIPTION	VOLTAGE
DTPM-1000-1B	+1.0°C to +6.0°C, sounds on rise and fall.	115VAC @ 60Hz
DTPM-1000-2A	+1.0°C to +6.0°C, sounds on rise and fall.	220VAC @ 50Hz
DTPM-1001-1B	+1.0°C to +10.0°C, sounds on rise and fall.	115VAC @ 60Hz
DTPM-1001-2A	+1.0°C to +10.0°C, sounds on rise and fall.	220VAC @ 50Hz
DTPM-3000-1B	-20°C, sounds on rising only.	115VAC @ 60Hz
DTPM-3000-2A	-20°C, sounds on rising only.	220VAC @ 50Hz
DTPM-3001-1B	-10°C, sounds on rising only.	115VAC @ 60Hz
DTPM-3001-2A	-10°C, sounds on rising only.	220VAC @ 50Hz

OPTIONAL DTPM TEMPERATURE CONFIGURATIONS

DTPM-1000 SERIES	DTPM-3000 SERIES
-2.0°C to +8.0°C	-10°C
+1.0°C to +8.0°C	-20°C
+1.0°C to +10.0°C	-22°C
+1.5°C to +5.5°C	-30°C
+1.5°C to +7.5°C	
+2.0°C to +6.0°C	
+2.0°C to +8.0°C	
+2.2°C to +2.7°C	
+2.5°C to +5.5°C	
+10.0°C to +15.0°C	
+20.0°C to +24.0°C	

US DOMESTIC WARRANTY

For a period of two (2) years, Digital Instruments, Inc. will supply at no charge, including freight, any replacement parts that fail due to defects in materials or workmanship under normal use. The Digital Instruments, Inc. one (1) year warranty applies to products sold outside the contiguous states. Inspection of defective parts by Digital Instruments, Inc. will be final in determining warranty status. Defective parts must be returned, prepaid, with return authorization number to Digital Instruments, Inc.

For a period of one (1) year, Digital Instruments will pay labor charges (including travel) and cost of supplies necessary to perform authorized repairs to Digital Instruments, Inc. products. Repair service must be performed by a recommended Digital Instruments, Inc. Service Agency. All services must be authorized by Digital Instruments, Inc. prior to performance of same to be covered by this warranty.

The following conditions apply:

- (1) The Digital Instruments Inc. warranty becomes effective two (2) weeks after shipment from our factory. This allows adequate shipping time so that commencement of the warranty coincides with the delivery of your new equipment.
- (2) The warranty does not apply to products damaged in transit or by accident, fire, flood, acts of God, unauthorized alteration, repair or improper installation. Digital Instruments Inc. warranties shall not be effective or actionable unless the equipment is used in accordance with all accompanying warnings and directions.
- (3) Digital Instrument, Inc. shall not be liable for loss of stored product.

This warranty supersedes all other warranties, expressed or implied. Digital Instruments, Inc. offers no warranty of merchantability or fitness for a particular purpose regarding goods sold. No agent, employee or representative of Digital Instruments, Inc. may bind Digital Instruments, Inc. to any warranty concerning equipment sold in addition to the warranty set forth. Any warranty, affirmation, affirmation or representation beyond the above term and conditions shall be non-enforceable.

INTERNATIONAL WARRANTY

Digital Instruments, Inc. warrants each new piece of equipment manufactured by us, to be free from defects in material and workmanship under normal use and service for one year.

If any part of said equipment should show any defects in materials or workmanship within one year of installation by the original purchaser, we will repair or replace the defective parts subject to the following conditions:

- (1) Installation must be made within 90 days from the date of shipment to the original purchaser. (Warranty card must be returned immediately after installation.)
- (2) The defective part shall be returned to us with transportation charges prepaid. The repaired or replaced part will be returned F.O.B. to our factory.
- (3) Warranty does not include any labor charges for removal or replacement of defective parts.
- (4) The warranty will not apply to any equipment which has been repaired or altered outside of the factory without specific authorization.
- (5) This warranty does not cover any loss of stored products.
- (6) This warranty supersedes all other warranties expressed or implied, and we neither assume nor authorize any other person to assume for us other liability in connection with the sale of our products.

TECHNICAL SUPPORT AND RETURN MATERIAL AUTHORIZATION (RMA)

Please call 716-874-5848 or 800-779-2909 to notify Digital Instruments, Inc. of problems during the warranty period. To identify the product, please supply:

- (a) Model Number
- (b) Serial Number
- (c) Full Description of Problem
- (d) Location of Product

Questions regarding operation, maintenance or product service may also be directed to the above toll-free number.



Digital Instruments, Inc.
580 Ensminger Road
Tonawanda, NY 14150
716-874-5848 or 800-779-2909
support@digitalinstruments.com
www.digitalinstruments.com